

INSTALLATION INSTRUCTIONS:

STEP 1

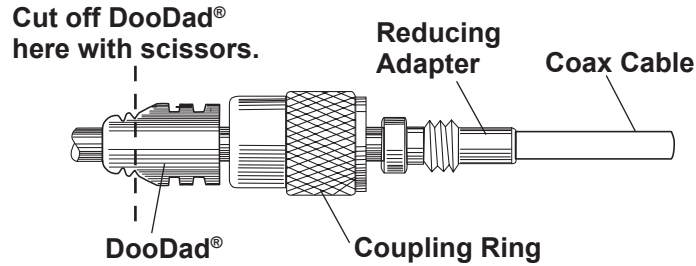

Trim DooDad® Cable Strain Relief to fit cable, as illustrated. Slide DooDad®, coupling ring, and reducing adapter onto the cable in the order and orientation shown.

STEP 2

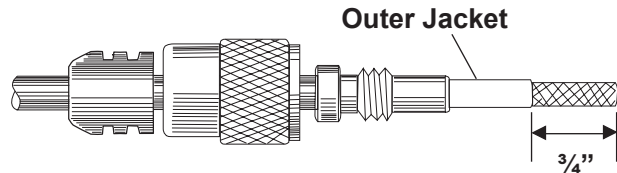

Prepare the cable according to the dimensions shown above.

STEP 3

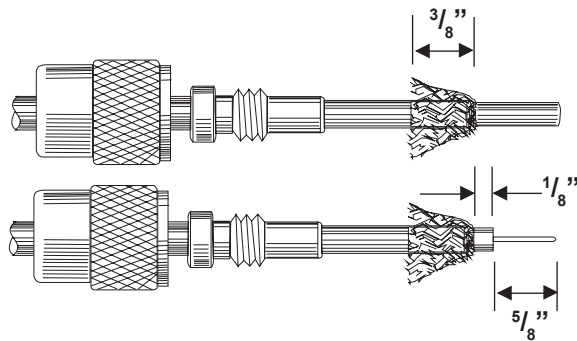

Fan the braid back, as illustrated, and trim it to 3/8". Strip the insulation from the center conductor as shown. **Be careful not to damage the center conductor.**

STEP 4

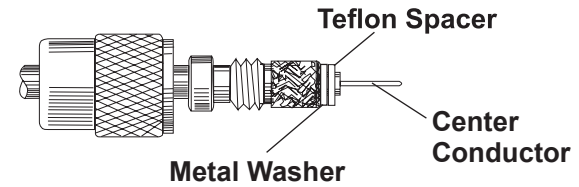

Position the adapter flush with the front edge of the cable's outer jacket and fold the braid back, over the end of the adapter as shown above. Gently twist the center conductor to bind any loose strands and carefully apply a very thin, even layer of solder to it. Slide the metal washer and the Teflon spacer onto the cable in the order illustrated above **(See Tech Note)**.

STEP 5

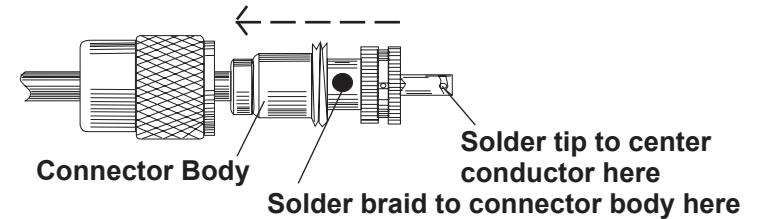

(See Tech Note) Screw the connector body tightly onto the reducing adapter and solder the tip to the center conductor. Trim off any excess center conductor. Solder the braid to the connector body through the holes. Screw the coupling ring on, and slide the DooDad® Cable Strain Relief snugly onto the rear of the completed connector.

TECH NOTE

If you prefer a complete solder installation, **do not use** the metal washer or Teflon spacer. At Step 5, solder the tip, and then solder the braid to the connector body through the four small holes in the connector body. **Be careful not to overheat the connector.** Complete the installation as described above.

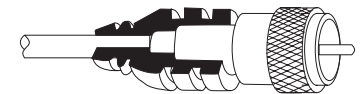

Finished connector, showing cutaway view of DooDad® in place

SHAKESPEARE® MARINE

www.shakespeare-marine.com

U.S. Operations: 6111 Shakespeare Rd. · Columbia, SC 29223 · 803-227-1590 · 800-845-7750

U.K. Operations: Enterprise Way, Fleetwood, Lancashire, FY7 8RY, England

+44 (0) 1253 858787 · Fax: +44 (0) 1253-859595